



VALVE-REGULATED BATTERY

12AVR-125L 12AVR-125LLP

FEATURES

- Pure lead positive grids
- Front access terminals
- Absorbed glass mat separators
- Tank formed plates
- Flame retardant polypropylene – UL94, VØ 28% LOI jar and cover
- Flame arrestor
- Self sealing vents
- Epoxy post seals
- Design life 10 years @ 77°F (full float)

SPECIFICATIONS

Rating: 120 ah @ 8 hr rate to 1.75 vpc,
125 ah @ 10 hr rate to 1.75 vpc

Float Voltage: 13.50 v.p.b. @ 77°F (25°C)

Weight: 120 lbs. (54.4 Kg)



QUALITY SYSTEM
CERTIFIED TO
ISO 9001
QS 9000

DISCHARGE RATE IN AMPS

Volts Per Cell (V.P.C.)	1 HR	3 HR	5 HR	8 HR	10 HR	15 HR	20 HR	24 HR
1.75	76.80	32.93	22.37	15.36	12.67	8.83	6.86	5.88
1.80	75.84	32.64	22.08	15.17	12.48	8.64	6.72	5.76
1.82	73.92	31.78	21.60	14.69	12.29	8.16	6.53	5.71
1.84	70.08	30.91	20.64	14.40	12.00	7.68	6.34	5.66
1.86	69.12	30.24	18.91	13.92	11.81	6.72	6.24	5.62
1.88	65.28	29.76	16.80	13.44	11.52	6.24	6.05	5.57
1.90	62.40	28.32	14.40	12.96	11.04	6.05	5.95	5.47

EAST PENN manufacturing co., inc.

Lyon Station, PA 19536-0147 • Phone: 610-682-6361 • Fax: 610-682-4781

Order Department Hotline: 610-682-4231

www.dekabatteries.com • E-mail: sales@eastpennunigy.com



Product Code	Nominal Voltage	Ampere Hours @ 8-hour Rate	Ampere Hours @ 10-hour Rate	Length	Width	Height	Total Weight	Acid Volume
12AVR-125L	12V	120	125	16.82 in. 427.2 mm	6.97 in. 177.0 mm	10.10 in. 256.5 mm	120lbs. 54.4 kg	2 gal. 7.57 L
12AVR-125LLP	12V	120	125	17.90 in. 454.7 mm	6.97 in. 177.0 mm	9.36 in. 237.7 mm	120lbs. 54.4 kg	2 gal. 7.57 L

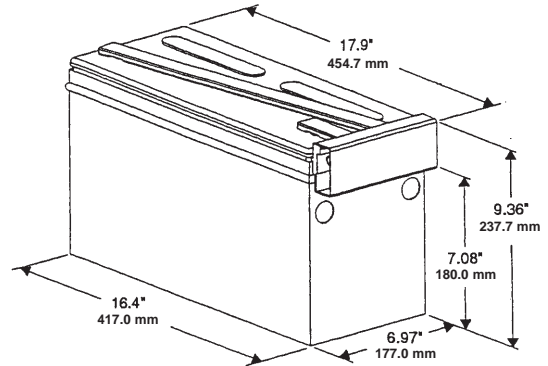
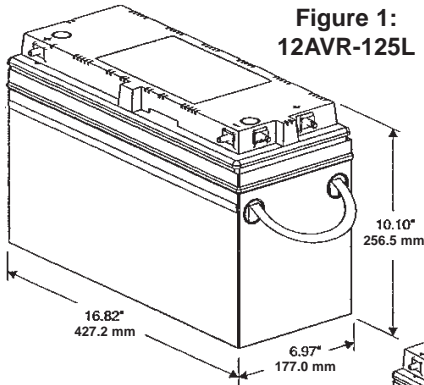

**Figure 2:
12AVR-125L
Bus Bar**

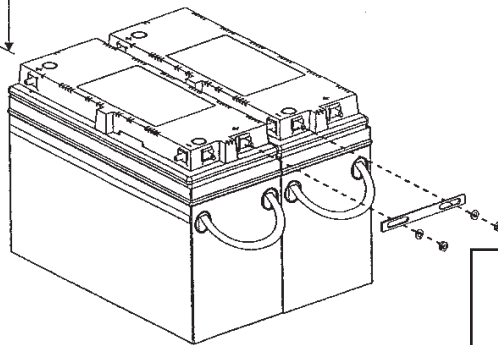

**Figure 5: Inter-Battery Connections
of 12AVR-125LLP**

