

CELLYTE 2CMT Range

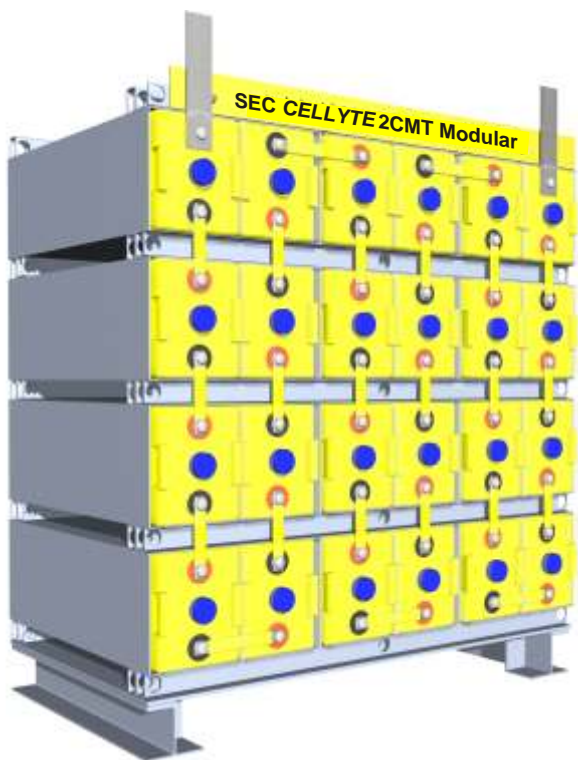

STATIONARY MODULAR / TUBULAR BATTERIES USING AGM TECHNOLOGY

20 YEARS DESIGN LIFE IN FLOAT SERVICE @ 20C



**HORIZONTAL LAYOUT MINIMISES
BATTERY FOOT PRINT**

**Sealed Valve Regulated
Maintenance Free
Lead Acid Batteries**

**CAPACITY 100 Ah. TO 4500 Ah.
C/10 RATE TO 1.80 Vpc @ 20C
or C/8 to 1.75 Vpc @ 25C**



**CADMIUM FREE
FULLY RECYCLABLE
LEAD ACID BATTERIES**
CONFORMS TO THE EUROPEAN
E.C.1992 DIRECTIVE ON
DANGEROUS SUBSTANCES

INNOVATIVE FEATURES

- * Valve regulated with Catalyst
- * Proprietary virgin Lead 1.6% Tin Alloy
- * Fully tank formed plates
- * Uniform cell cooling
- * Increased Capacity with Catalyst
- * Never requires addition of water
- * Spill proof and leak proof
- * Very low gassing on float charge
- * Explosion proof / Increased safety
- * Operates at low internal pressure
- * For use in vertical or horizontal positions

APPLICATIONS

- * Telecommunications
- * UPS
- * Emergency Lighting
- * Standby Power
- * Switchgear
- * Control System
- * Cellular Radio
- * Navigation Aids
- * Photovoltaic/Solar
- * Wind & Alternative Energy

Supplied Worldwide by:

SEC Industrial Battery Co.



CELLYTE 2CMT - Modular/Tubular Dimensions, Weights & Data

SEC Battery TYPE	Capacity C/10 1.80 vpc	Single Cell Sizes	CELL DIMENSIONS & WEIGHT					24 CELL BATTERY DIMENSIONS mm				Internal Resist. m Ohms	1 Minute Rate to 1.67 vpc	Short Circuit Current	No. of Terminal Post
			Length mm	Width mm	Height mm H1	Height mm H2	CELL KG	Length Mod./Tub.	Depth Mod.&Tub.	Height Mod.&Tub.	Weight KG				
2CMT100	100	1 x 100	102	187	278	300	7.0	672 / 720	310	1010	200	0.70	216	1080	2
2CMT150	150	1 x 150	102	187	278	300	10	672 / 720	310	1010	288	0.60	300	1500	2
2CMT200	200	1 x 200	102	187	278	300	15	672 / 720	310	1010	432	0.50	340	1600	2
2CMT250	250	1 x 250	102	187	374	396	17	672 / 720	410	1010	490	0.45	380	1900	2
2CMT300	300	1 x 300	102	187	374	396	21	672 / 720	410	1010	605	0.40	480	2400	2
2CMT350	350	1 x 350	151	187	374	396	25	966 / 1010	410	1010	720	0.39	580	2900	2
2CMT400	400	1 x 400	151	187	374	396	28	966 / 1010	410	1010	810	0.36	640	3200	2
2CMT450	450	1 x 450	151	187	374	396	32	966 / 1010	410	1010	925	0.33	720	3600	2
2CMT500	500	1 x 500	151	187	543	565	34	966 / 1010	580	1010	980	0.30	800	4000	2
2CMT550	550	1 x 550	151	187	543	565	36	966 / 1010	580	1010	1040	0.29	900	4500	2
2CMT600	600	1 x 600	151	187	543	565	38	966 / 1010	580	1010	1100	0.28	970	4800	2
2CMT650	650	1 x 650	151	187	543	565	41	966 / 1010	580	1010	1180	0.24	1030	5100	2
2CMT700	700	1 x 700	151	187	543	565	45	966 / 1010	580	1010	1300	0.23	1120	5600	2
2CMT750	750	1 x 750	223	187	543	565	48	958 / 980	580	1500	1380	0.22	1200	6000	4
2CMT800	800	1 x 800	223	187	543	565	58	958 / 980	580	1500	1670	0.20	1280	6400	4
2CMT850	850	1 x 850	223	187	543	565	61	958 / 980	580	1500	1760	0.190	1380	6900	4
2CMT900	900	1 x 900	223	187	543	565	65	958 / 980	580	1500	1875	0.180	1460	7300	4
2CMT1000	1000	1 x 1000	223	187	543	565	68	958 / 980	580	1500	1960	0.160	1580	7900	4
2CMT1100	1100	1 x 1100	223	187	543	565	74	958 / 980	580	1500	2130	0.140	1720	8600	4
2CMT1200	1200	1 x 1200	223	187	643	665	78	958 / 980	680	1500	2250	0.130	1800	9000	4
2CMT1300	1300	1 x 1300	223	187	643	665	82	958 / 980	680	1500	2360	0.125	1900	9500	4
2CMT1400	1400	1 x 1400	223	187	643	665	88	958 / 980	680	1500	2540	0.120	2100	10500	4
2CMT1500	1500	1 x 1500	223	187	643	665	96	958 / 980	680	1500	2765	0.110	2380	11900	4
2CMT1600	1600	2 x 800	2 x 223	187	543	565	2 x 58	1916 / 1940	580	1500	3340	0.100	2560	12800	8
2CMT1700	1700	2 x 850	2 x 223	187	543	565	2 x 61	1916 / 1940	580	1500	3520	0.095	2760	13800	8
2CMT1800	1800	2 x 900	2 x 223	187	543	565	2 x 65	1916 / 1940	580	1500	3750	0.090	2920	14600	8
2CMT2000	2000	2 x 1000	2 x 223	187	543	565	2 x 68	1916 / 1940	580	1500	3920	0.080	2060	15800	8
2CMT2200	2200	2 x 1100	2 x 223	187	543	565	2 x 74	1916 / 1940	580	1500	4260	0.070	2240	17200	8
2CMT2400	2400	2 x 1200	2 x 223	187	643	665	2 x 78	1916 / 1940	680	1500	4500	0.065	2400	18000	8
2CMT2600	2600	2 x 1300	2 x 223	187	643	665	2 x 82	1916 / 1940	680	1500	4720	0.063	2560	19000	8
2CMT2800	2800	2 x 1400	2 x 223	187	643	665	2 x 88	1916 / 1940	680	1500	5080	0.060	2760	21000	8
2CMT3000	3000	2 x 1500	2 x 223	187	643	665	2 x 96	1916 / 1940	680	1500	5530	0.055	2920	23800	8
2CMT3300	3300	3 x 1100	3 x 223	187	543	565	3 x 74	2220 / 2250	580	2130	6390	0.047	5160	25800	12
2CMT3600	3600	3 x 1200	3 x 223	187	643	665	3 x 78	2220 / 2250	680	2130	6750	0.043	5400	27000	12
2CMT3900	3900	3 x 1300	3 x 223	187	643	665	3 x 82	2220 / 2250	680	2130	7080	0.042	5700	28500	12
2CMT4200	4200	3 x 1400	3 x 223	187	643	665	3 x 88	2220 / 2250	680	2130	7620	0.040	6300	31500	12
2CMT4500	4500	3 x 1500	3 x 223	187	643	665	3 x 96	2220 / 2250	680	2130	8295	0.037	7140	35700	12

Actual discharge data may be +/- 5% of data shown - Single cells over 1500 ah not available until early 2006

CELLYTE 2CMT Cell - Cutaway View

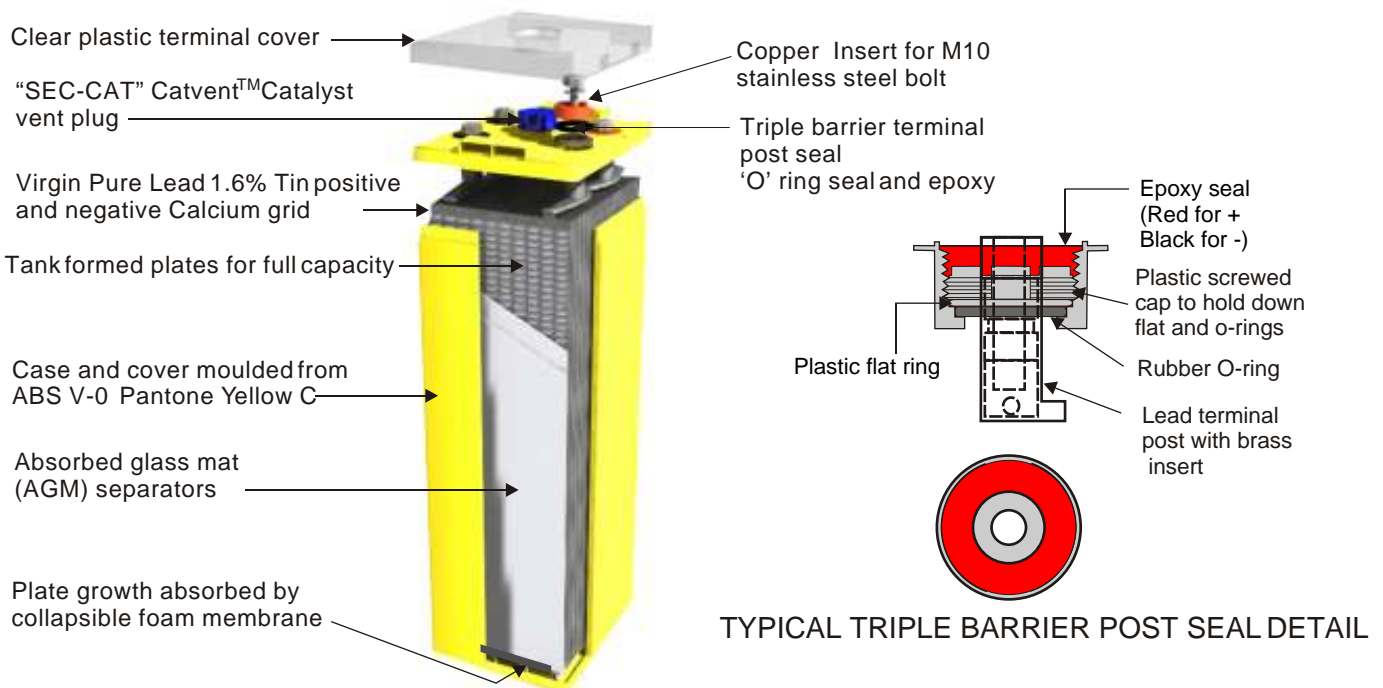

Heavy duty ABS cell jar can be free standing or in a zone 4 modular rack

CELLYTE 2CMT Modular/Tubular - Ampere Hour Data to 1.80 vpc @ 20 C.

SEC Battery TYPE	END Volts / Cell	DATA AMPS @ 20 C						END Volts / Cell	DISCHARGE DATA AMPS HOURS TO 1.80 vpc @ 20 C											
		DISCHARGE TIME IN MINUTES							DISCHARGE TIME IN HOURS											
		5	10	15	20	30	45		1	1.5	2	3	4	5	6	8	10	12	24	
2CMT100	1.75	161	140	126	112	91.5	73.2	1.80	57.0	63.0	68.0	76.0	82.0	86.0	89.0	98.0	100	103	111	
2CMT150	1.75	242	211	189	168	137	110	1.80	85.5	94.5	102	114	123	129	134	147	150	155	167	
2CMT200	1.75	322	281	251	224	183	146	1.80	114	126	136	152	164	172	178	196	200	206	222	
2CMT250	1.75	403	351	314	280	229	183	1.80	143	158	170	190	205	215	223	245	250	258	278	
2CMT300	1.75	483	421	377	336	274	219	1.80	171	189	204	228	246	258	267	294	300	309	333	
2CMT350	1.75	564	491	440	392	320	256	1.80	200	221	238	266	287	301	312	343	350	361	389	
2CMT400	1.75	644	562	503	448	366	293	1.80	228	252	272	304	328	344	356	392	400	412	444	
2CMT450	1.75	725	632	566	504	412	329	1.80	257	284	306	342	369	387	401	441	450	464	500	
2CMT500	1.75	805	702	628	561	457	366	1.80	285	315	340	380	410	430	445	490	500	515	555	
2CMT550	1.75	886	772	691	617	503	402	1.80	314	347	374	418	451	473	490	539	550	567	611	
2CMT600	1.75	966	843	754	673	549	439	1.80	342	378	408	456	492	516	534	588	600	618	666	
2CMT650	1.75	1047	913	817	729	594	476	1.80	371	410	442	494	533	559	579	637	650	670	722	
2CMT700	1.75	1127	983	880	785	640	512	1.80	399	441	476	532	574	602	623	686	700	721	777	
2CMT750	1.75	1208	1053	943	841	686	549	1.80	428	473	510	570	615	645	668	735	750	773	833	
2CMT800	1.75	1289	1123	1005	897	732	585	1.80	456	504	544	608	656	688	712	784	800	824	888	
2CMT850	1.75	1369	1194	1068	953	777	622	1.80	485	536	578	646	697	731	757	833	850	876	944	
2CMT900	1.75	1450	1264	1131	1009	823	658	1.80	513	567	612	684	738	774	801	882	900	927	999	
2CMT1000	1.75	1611	1404	1257	1121	915	732	1.80	570	630	680	760	820	860	890	980	1000	1030	1110	
2CMT1100	1.75	1772	1545	1382	1233	1006	805	1.80	627	693	748	836	902	946	979	1078	1100	1133	1221	
2CMT1200	1.75	1933	1685	1508	1345	1097	878	1.80	684	756	816	912	984	1032	1068	1176	1200	1236	1332	
2CMT1300	1.75	2094	1825	1634	1457	1189	951	1.80	741	819	884	988	1066	1118	1157	1274	1300	1339	1443	
2CMT1400	1.75	2255	1966	1759	1569	1280	1024	1.80	798	882	952	1064	1148	1204	1246	1372	1400	1442	1554	
2CMT1500	1.75	2416	2106	1885	1682	1372	1097	1.80	855	945	1020	1140	1230	1290	1335	1470	1500	1545	1665	
2CMT1600	1.75	2577	2247	2011	1794	1463	1171	1.80	912	1008	1088	1216	1312	1376	1424	1568	1600	1648	1776	
2CMT1700	1.75	2738	2387	2136	1906	1555	1244	1.80	969	1071	1156	1292	1394	1462	1513	1666	1700	1751	1887	
2CMT1800	1.75	2899	2528	2262	2018	1646	1317	1.80	1026	1134	1224	1368	1476	1548	1602	1764	1800	1854	1998	
2CMT2000	1.75	3221	2808	2513	2242	1829	1463	1.80	1140	1260	1360	1520	1640	1720	1780	1960	2000	2060	2220	
2CMT2200	1.75	3544	3089	2765	2466	2012	1610	1.80	1254	1386	1496	1672	1804	1892	1958	2156	2200	2266	2442	
2CMT2400	1.75	3866	3370	3016	2690	2195	1756	1.80	1368	1512	1632	1824	1968	2064	2136	2352	2400	2472	2664	
2CMT2600	1.75	4188	3651	3267	2915	2378	1902	1.80	1482	1638	1768	1976	2132	2236	2314	2548	2600	2678	2886	
2CMT2800	1.75	4510	3932	3519	3139	2561	2048	1.80	1596	1764	1904	2128	2296	2408	2492	2744	2800	2884	3108	
2CMT3000	1.75	4832	4213	3770	3363	2744	2195	1.80	1710	1890	2040	2280	2460	2580	2670	2940	3000	3090	3330	
2CMT3300	1.75	5154	4493	4021	3587	2926	2341	1.80	1824	2016	2176	2432	2624	2752	2848	3136	3200	3296	3552	
2CMT3600	1.75	5799	5055	4524	4036	3292	2634	1.80	2052	2268	2448	2736	2952	3096	3204	3528	3600	3708	3996	
2CMT3900	1.75	6282	5476	4901	4372	3567	2853	1.80	2223	2457	2652	2964	3198	3354	3471	3822	3900	4017	4329	
2CMT4200	1.75	6765	5898	5278	4708	3841	3073	1.80	2394	2646	2856	3192	3444	3612	3738	4116	4200	4326	4662	
2CMT4500	1.75	7248	6319	5655	5045	4115	3292	1.80	2565	2835	3060	3420	3690	3870	4005	4410	4500	4635	4995	

Actual discharge data may be +/- 5% of data shown - Single cells over 1500 ah not available until 2006

Typical Modular Zone 4 Racks for 48 Volt Systems

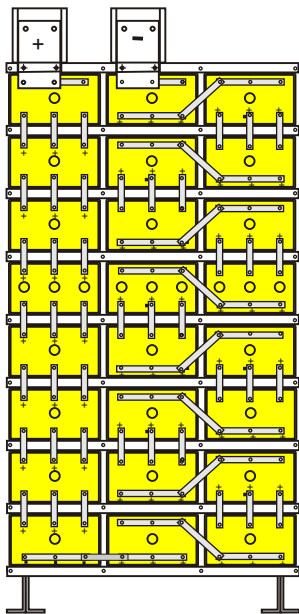

Front view
24 x 2CMT
6 post cells

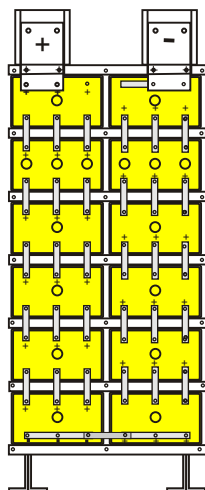

Front view
12 x 2CMT
6 post cells

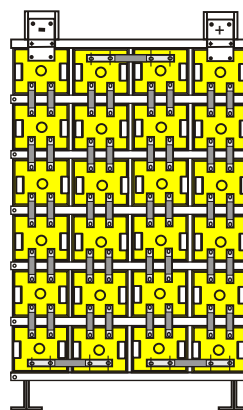

Front view
24 x 2CMT
4 post cells

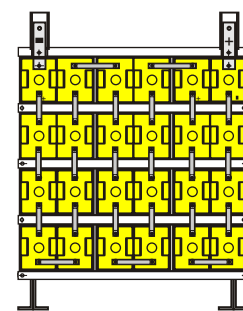

Front view
24 x 2CMT
2 post cells

CELLYTE 2CMT Modular/Tubular - Data Amps to 1.80 vpc @ 20 C.

SEC Battery TYPE	END Volts / Cell	DATA AMPS @ 20 C						END Volts / Cell	DISCHARGE DATA AMPS TO 1.80 vpc @ 20 C											
		DISCHARGE TIME IN MINUTES							DISCHARGE TIME IN HOURS											
		5	10	15	20	30	45		1	1.5	2	3	4	5	6	8	10	12	24	
2CMT100	1.75	161	140	126	112	91.5	73.2	1.80	57.0	42.0	34.0	25.3	20.5	17.2	14.8	12.3	10.0	8.6	4.6	
2CMT150	1.75	242	211	189	168	137	110	1.80	85.5	63.0	51.0	38.0	30.8	25.8	22.3	18.4	15.0	12.9	6.9	
2CMT200	1.75	322	281	251	224	183	146	1.80	114	84.0	68.0	50.7	41.0	34.4	29.7	24.5	20.0	17.2	9.3	
2CMT250	1.75	403	351	314	280	229	183	1.80	143	105	85.0	63.3	51.3	43.0	37.1	30.6	25.0	21.5	11.6	
2CMT300	1.75	483	421	377	336	274	219	1.80	171	126	102	76.0	61.5	51.6	44.5	36.8	30.0	25.8	13.9	
2CMT350	1.75	564	491	440	392	320	256	1.80	200	147	119	88.7	71.8	60.2	51.9	42.9	35.0	30.0	16.2	
2CMT400	1.75	644	562	503	448	366	293	1.80	228	168	136	101	82.0	68.8	59.3	49.0	40.0	34.3	18.5	
2CMT450	1.75	725	632	566	504	412	329	1.80	257	189	153	114	92.3	77.4	66.8	55.1	45.0	38.6	20.8	
2CMT500	1.75	805	702	628	561	457	366	1.80	285	210	170	127	103	86.0	74.2	61.3	50.0	42.9	23.1	
2CMT550	1.75	886	772	691	617	503	402	1.80	314	231	187	139	113	94.6	81.6	67.4	55.0	47.2	25.4	
2CMT600	1.75	966	843	754	673	549	439	1.80	342	252	204	152	123	103	89.0	73.5	60.0	51.5	27.8	
2CMT650	1.75	1047	913	817	729	594	476	1.80	371	273	221	165	133	112	96.4	79.6	65.0	55.8	30.1	
2CMT700	1.75	1127	983	880	785	640	512	1.80	399	294	238	177	144	120	104	85.8	70.0	60.1	32.4	
2CMT750	1.75	1208	1053	943	841	686	549	1.80	428	315	255	190	154	129	111	91.9	75.0	64.4	34.7	
2CMT800	1.75	1289	1123	1005	897	732	585	1.80	456	336	272	203	164	138	119	98.0	80.0	68.7	37.0	
2CMT850	1.75	1369	1194	1068	953	777	622	1.80	485	357	289	215	174	146	126	104	85.0	73.0	39.3	
2CMT900	1.75	1450	1264	1131	1009	823	658	1.80	513	378	306	228	185	155	134	110	90.0	77.3	41.6	
2CMT1000	1.75	1611	1404	1257	1121	915	732	1.80	570	420	340	253	205	172	148	123	100	85.8	46.3	
2CMT1100	1.75	1772	1545	1382	1233	1006	805	1.80	627	462	374	279	226	189	163	135	110	94.4	50.9	
2CMT1200	1.75	1933	1685	1508	1345	1097	878	1.80	684	504	408	304	246	206	178	147	120	103	55.5	
2CMT1300	1.75	2094	1825	1634	1457	1189	951	1.80	741	546	442	329	267	224	193	159	130	112	60.1	
2CMT1400	1.75	2255	1966	1759	1569	1280	1024	1.80	798	588	476	355	287	241	208	172	140	120	64.8	
2CMT1500	1.75	2416	2106	1885	1682	1372	1097	1.80	855	630	510	380	308	258	223	184	150	129	69.4	
2CMT1600	1.75	2577	2247	2011	1794	1463	1171	1.80	912	672	544	405	328	275	237	196	160	137	74.0	
2CMT1700	1.75	2738	2387	2136	1906	1555	1244	1.80	969	714	578	431	349	292	252	208	170	146	78.6	
2CMT1800	1.75	2899	2528	2262	2018	1646	1317	1.80	1026	756	612	456	369	310	267	221	180	155	83.3	
2CMT2000	1.75	3221	2808	2513	2242	1829	1463	1.80	1140	840	680	507	410	344	297	245	200	172	92.5	
2CMT2200	1.75	3544	3089	2765	2466	2012	1610	1.80	1254	924	748	557	451	378	326	270	220	189	102	
2CMT2400	1.75	3866	3370	3016	2690	2195	1756	1.80	1368	1008	816	608	492	413	356	294	240	206	111	
2CMT2600	1.75	4188	3651	3267	2915	2378	1902	1.80	1482	1092	884	659	533	447	386	319	260	223	120	
2CMT2800	1.75	4510	3932	3519	3139	2561	2048	1.80	1596	1176	952	709	574	482	415	343	280	240	130	
2CMT3000	1.75	4832	4213	3770	3363	2744	2195	1.80	1710	1260	1020	760	615	516	445	368	300	258	139	
2CMT3300	1.75	5154	4493	4021	3587	2926	2341	1.80	1824	1344	1088	811	656	550	475	392	320	275	148	
2CMT3600	1.75	5799	5055	4524	4036	3292	2634	1.80	2052	1512	1224	912	738	619	534	441	360	309	167	
2CMT3900	1.75	6282	5476	4901	4372	3567	2853	1.80	2223	1638	1326	988	800	671	579	478	390	335	180	
2CMT4200	1.75	6765	5898	5278	4708	3841	3073	1.80	2394	1764	1428	1064	861	722	623	515	420	361	194	
2CMT4500	1.75	7248	6319	5655	5045	4115	3292	1.80	2565	1890	1530	1140	923	774	668	551	450	386	208	

Actual discharge data may be +/- 5% of data shown - Single cells over 1500 ah not available until early 2006

Typical Tubular Zone 0 racks for 48Volt System

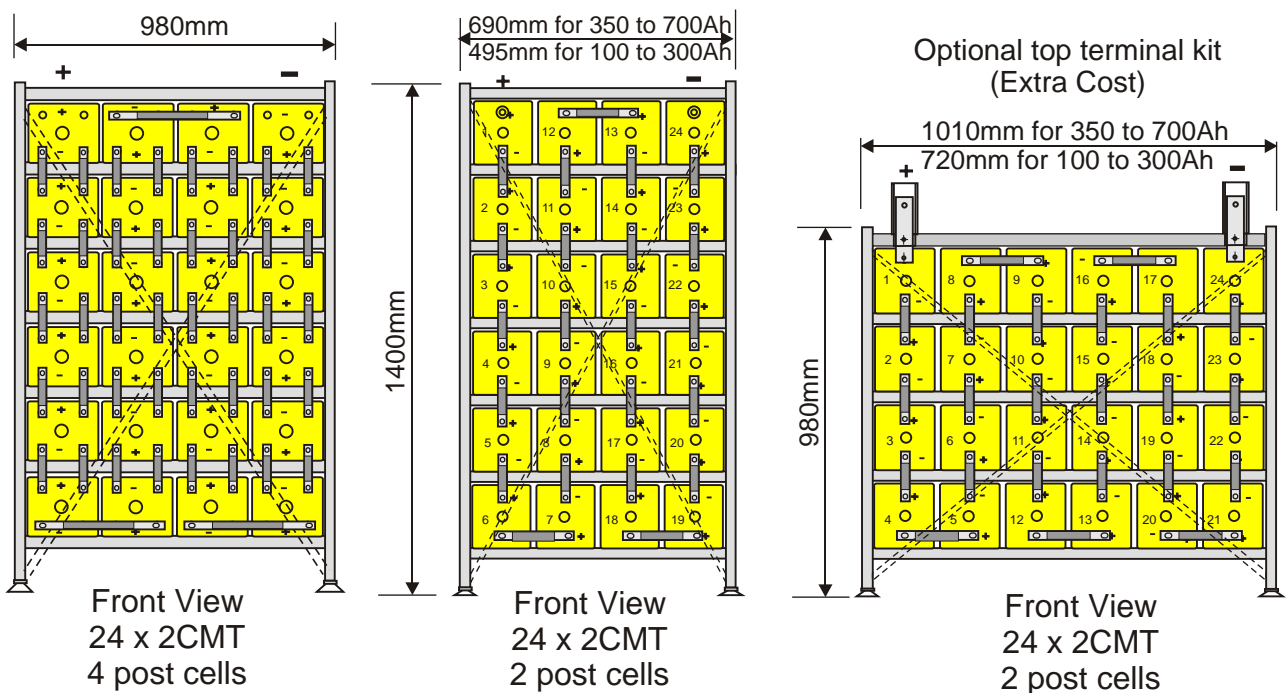

CELLYTE 2CMT Modular/Tubular - Watts to 1.67/1.75 vpc @ 20 C.

SEC Battery TYPE	END	DISCHARGE Watts per Cell at 20 C						END	DISCHARGE DATA Watts Per Cell AT 20 C									
	Volts / Cell	DISCHARGE TIME IN MINUTES						Volts / Cell	DISCHARGE TIME IN HOURS									
		5	10	15	20	30	45		1	1.5	2	3	4	5	6	8	10	
2CMT100	1.67	284	263	247	222	174	136	1.75	115	82.4	67.2	51.0	41.6	34.7	30.0	24.2	20.0	
2CMT150	1.67	426	395	371	332	261	204	1.75	173	124	101	76.5	62.4	52.1	44.9	36.3	30.0	
2CMT200	1.67	568	526	494	443	348	272	1.75	230	165	134	102	83.2	69.5	59.9	48.4	40.0	
2CMT250	1.67	710	658	618	554	435	340	1.75	288	206	168	128	104	86.8	74.9	60.5	50.0	
2CMT300	1.67	852	789	741	665	522	408	1.75	346	247	202	153	125	104	89.9	72.6	60.0	
2CMT350	1.67	994	921	865	776	609	476	1.75	403	288	235	179	146	122	105	84.7	70.0	
2CMT400	1.67	1137	1052	988	886	696	544	1.75	461	330	269	204	166	139	120	96.8	80.0	
2CMT450	1.67	1279	1184	1112	997	783	612	1.75	518	371	302	230	187	156	135	109	90.0	
2CMT500	1.67	1421	1315	1235	1108	869	680	1.75	576	412	336	255	208	174	150	121	100	
2CMT550	1.67	1563	1447	1359	1219	956	748	1.75	634	453	370	281	229	191	165	133	110	
2CMT600	1.67	1705	1578	1482	1330	1043	816	1.75	691	494	403	306	250	208	180	145	120	
2CMT650	1.67	1847	1710	1606	1440	1130	884	1.75	749	536	437	332	270	226	195	157	130	
2CMT700	1.67	1989	1841	1729	1551	1217	952	1.75	806	577	470	357	291	243	210	169	140	
2CMT750	1.67	2131	1973	1853	1662	1304	1020	1.75	864	618	504	383	312	261	225	182	150	
2CMT800	1.67	2273	2104	1976	1773	1391	1088	1.75	922	659	537	408	333	278	240	194	160	
2CMT850	1.67	2415	2236	2100	1884	1478	1157	1.75	979	700	571	434	354	295	255	206	170	
2CMT900	1.67	2557	2367	2223	1994	1565	1225	1.75	1037	742	605	459	374	313	270	218	180	
2CMT1000	1.67	2841	2630	2470	2216	1739	1361	1.75	1152	824	672	510	416	347	300	242	200	
2CMT1100	1.67	3125	2894	2717	2438	1913	1497	1.75	1267	907	739	561	458	382	330	266	220	
2CMT1200	1.67	3410	3157	2964	2659	2087	1633	1.75	1382	989	806	612	499	417	360	291	240	
2CMT1300	1.67	3694	3420	3211	2881	2261	1769	1.75	1498	1071	873	663	541	452	389	315	260	
2CMT1400	1.67	3978	3683	3458	3102	2435	1905	1.75	1613	1154	941	714	582	486	419	339	280	
2CMT1500	1.67	4262	3946	3705	3324	2608	2041	1.75	1728	1236	1008	765	624	521	449	363	300	
2CMT1600	1.67	4546	4209	3952	3546	2782	2177	1.75	1843	1319	1075	816	666	556	479	387	320	
2CMT1700	1.67	4830	4472	4199	3767	2956	2313	1.75	1958	1401	1142	868	707	591	509	412	340	
2CMT1800	1.67	5114	4735	4446	3989	3130	2449	1.75	2074	1483	1209	919	749	625	539	436	360	
2CMT2000	1.67	5683	5261	4940	4432	3478	2721	1.75	2304	1648	1344	1021	832	695	599	484	400	
2CMT2200	1.67	6251	5787	5434	4875	3826	2993	1.75	2534	1813	1478	1123	915	764	659	533	440	
2CMT2400	1.67	6819	6313	5928	5318	4173	3265	1.75	2765	1978	1612	1225	999	834	719	581	480	
2CMT2600	1.67	7387	6839	6422	5761	4521	3538	1.75	2995	2143	1747	1327	1082	903	779	629	520	
2CMT2800	1.67	7956	7365	6916	6205	4869	3810	1.75	3226	2308	1881	1429	1165	973	839	678	560	
2CMT3000	1.67	8524	7891	7411	6648	5217	4082	1.75	3456	2472	2016	1531	1248	1042	899	726	600	
2CMT3300	1.67	9092	8418	7905	7091	5565	4354	1.75	3686	2637	2150	1633	1331	1112	959	775	640	
2CMT3600	1.67	10229	9470	8893	7977	6260	4898	1.75	4493	3214	2620	1990	1623	1355	1168	944	780	
2CMT3900	1.67	11081	10259	9634	8642	6782	5306	1.75	4838	3461	2822	2143	1747	1459	1258	1017	840	
2CMT4200	1.67	11933	11048	10374	9307	7304	5714	1.75	5184	3708	3023	2296	1872	1563	1348	1089	900	
2CMT4500	1.67	12786	11837	11116	9972	7825	6123	1.75	5530	3956	3225	2449	1997	1667	1438	1162	960	

Actual discharge data may be +/- 5% of data shown - Single cells over 1500 ah not available until early 2006

CELLYTE 2CMT Modular/Tubular 2 Volt AGM-VRLA Stationary Batteries

The SEC **CELLYTE 2CMT Modular/Tubular** AGM Sealed, valve regulated VRLA battery line fitted with VRLA Catalyst is a range of long life sealed, valve regulated batteries that require very little maintenance and can be mounted in any space without special ventilation. The **CELLYTE 2CMT Modular/Tubular** battery is designed to provide service for twenty years when used in float service at 20°C. These cells / batteries comply with BS 6290 Part 4, with flame retardant V-0 case, EUROBAT and the new IEC 60896-21/22-2004 standard. This range may be installed in either a horizontal or vertical configuration, although for the larger cell sizes only the horizontal configuration is recommended because of improved service life, savings in floor space and ease of installation. The container and clear plastic cover have a flame retardant rating of UL94 V-0 cells but can also be provided in standard plastic. Cells can be supplied in a Seismic Zone 4 rated steel module rack or in a Zone 0 rated tubular steel rack. The steel modular or tubular racks are designed to provide strength, ease of handling, protection against shock and vibration damage, and allows for uniform cooling of all cells. SEC **CELLYTE 2CMT Modular / Tubular** cell plates are made from virgin pure lead 1.6% Tin alloy and are tank formed prior to assembly. The chemical composition, and morphological structure of the positive plate active material, is optimised to give plates and cells which have the highest possible service-life in float service and up to 1200 x 80% deep cycles. The battery end of life is defined as when the battery system can no longer deliver 80% of the rated capacity for which it was initially designed. Modular /Tubular batteries are clearly marked with the SEC battery reference, nominal capacity (C/10 to 1.8 Vpc 20 C or C/8 to 1.75 Vpc at 25C), environmental related information and date of manufacture.

Benefits of Catalyst in SEC VRLA Batteries

Catalyst Reduces Float Current

One of the most immediate, observable effects of installing a catalyst in a VRLA cell is a sudden drop in the float current. Typically float currents are one half or less when a catalyst is installed. Adding a catalyst to the cell prevents some of the oxygen reaching the negative plate and allows the negative plate to stay polarised. This means that less current needs to be supplied to the cell from the charging system, manifesting itself as lower float current, leading to the following benefit :-

* Minimize water loss

Gasses are recombined into water inside the cell rather than exiting the cell. Too much gas leaving the cell can lead to premature dry-out and cell failure. Cell dry is a major cause of VRLA cell failure

* Increased life

There are many potential failure modes of VRLA cells. A number of these failure modes can be mitigated by the catalyst technology such as: Cell dry out, positive plate corrosion, thermal runaway, capacity loss due to negative plate depolarization

* Minimize positive plate corrosion

A reduction in float current reduces the amount of over-charge on the positive plate which directly impacts the corrosion rate. The design life of a lead acid cell is based on the corrosion of the plate barring any other unforeseen failure modes.

* Maintain cell capacity

Many VRLA cells in service are failing capacity tests because their negative plates are depolarized. In fact significant capacity increases have been seen on some cells just by installing a catalyst.

“SEC-CAT” Catvent™ - Catalyst Vent Plug

SEC's **CELLYTE2CMT** VRLA cells incorporate the Philadelphia Scientific Precious Metal **Catvent™** to stabilise the negative plate, enhance the water recombination process within the cell, reduce cell dry out, reduces float current by up to 50%, positive plate corrosion, thermal runaway, and capacity loss due to negative plate polarisation. This makes the **CELLYTE2CMT** battery ideally suited for Telecom, UPS, Photovoltaic, Wind power, and other Float & Shallow Cyclic applications. Manufactured to Quality system certified to ISO 9001-2000

FEATURES :

The **CELLYTE 2CMT** 'High Integrity' high density battery is supplied as a free standing 2 volt vertical or horizontal cells in a Modular or Tubular steel racking system for minimum floor space, uniform cell cooling and extra long life. The Zone 4 Modular battery rack design provides a strong battery rack that is reduced in both height, width. The Zone 0 Tubular battery racks for use in regions that are not subject to earthquakes.

System Configuration:

24 and 48 volts for Telecommunications and 120, 240 and 480 volts for UPS, Power and Switchgear Control

Operating temperature : -25C to +55C

However we recommend that the batteries be operated in the temperature range of 20 to 25C, to obtain full life and optimum performance.

Applicable Standards

IEC 60896-21/22-2004

BS 6290 Part 4

Eurobat

UL Component approval

CYCLE LIFE

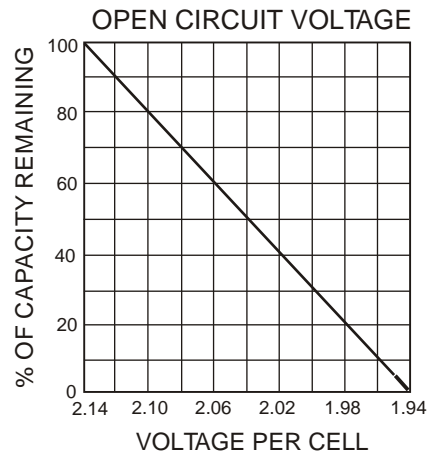
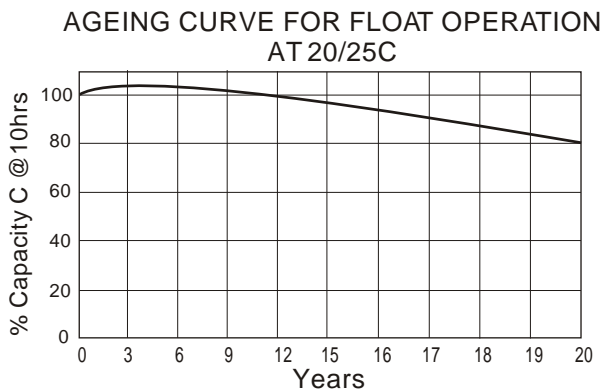
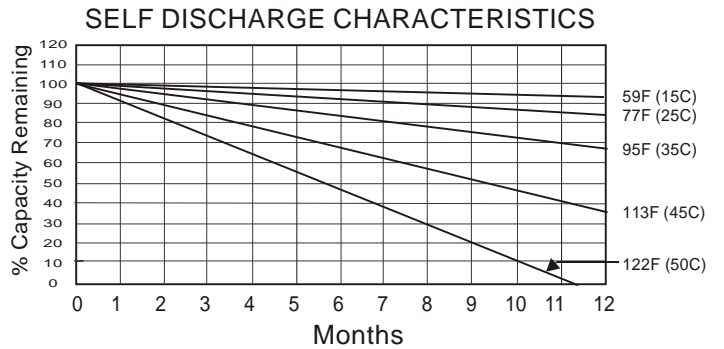
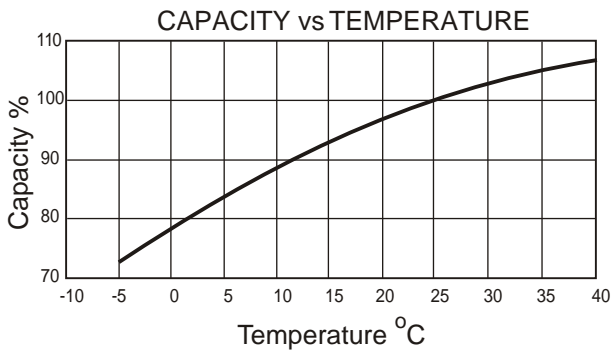
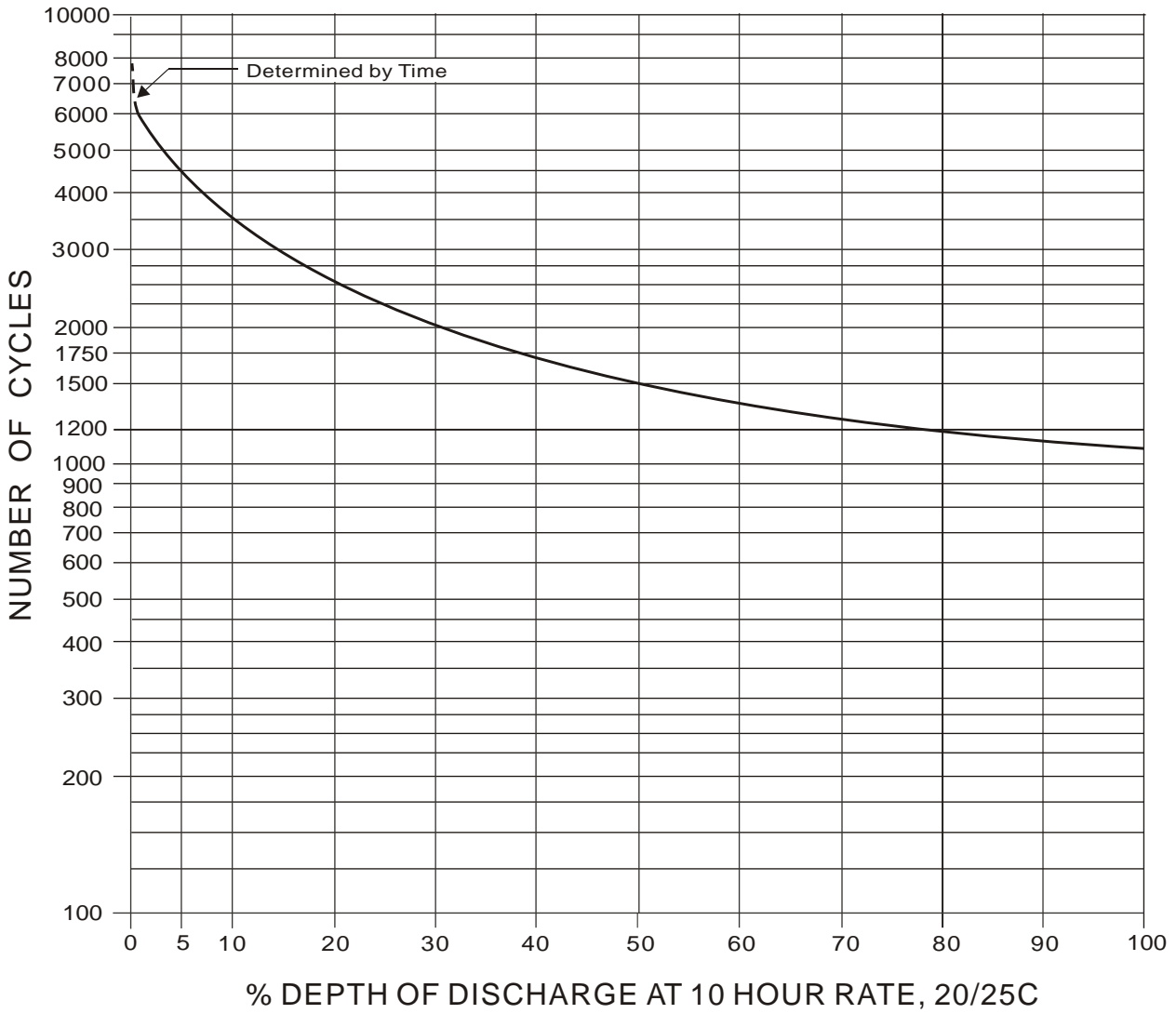

For all your Battery Needs from SEC's battery range

SEC have Batteries to suit all your needs with full range of Absorbed Glass Mat (AGM) for Float / Standby, and Gel Batteries for Cycling applications. 1.3 Ah. to over 4500 Ah.

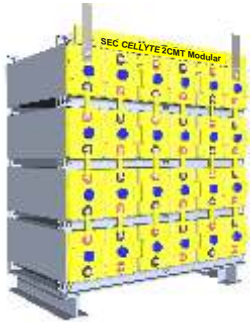

CELLYTE 2CMT Modular **CELLYTE 2TLAM/G Tubular** **CELLYTE 2TLAM/G Modular** **CELLYTE 2TLA Range**



CELLYTE 2TLG Range **CELLYTE 12FTA/G Range** **CELLYTE 6-12TLA Range** **CELLYTE 6-12TLG Range**



CELLYTE 6-12TUA Range **CELLYTE 6-12TSG Range** **MICROLYTE Plus Range** **MICROLYTE Gel Range**



MICROLYTE Red Top Range **SEC Gel OPzV Range** **SEC Tubular OPzS Range** **SEC Nickel Cadmium Range**

Visit our Web site for more product information on www.secbattery.com



The USA Sales Office
1643 Holicong Road
PO Box 849 Buckingham,
PA 18912, U.S.A.
Tel: 1 215 654 9334
Fax: 1 215 654 9871
ussalesoffice@secbattery.com

SEC Industrial Battery Co.Ltd.
Thorney Weir House, Iver
Bucks SLO 9AQ, ENGLAND
Tel. 44 1895 431543
Fax. 44 1895 431880
europeanoffice@secbattery.com

SEC Industrial Battery Co.
P.O.Box 32225
Kingdom of Bahrain
Tel: 97317 721322
Fax: 97317 740743
middleeastoffice@secbattery.com

SEC Industrial Battery Co.Ltd.
Unit 6, 6/f, Hewlett Centre
No. 54 Hoi Yuen Road, Kwun Tong
Kowloon, Hong Kong
Tel: 852 230 44382
Fax: 852 230 44013
fareastoffice@secbattery.com

SEC Industrial Battery Co., UK Warehouse
Unit 16 Alexander Court, Fleming Road,
Earlscotes Ind. Est. Corby, Northants, NN 17 4SW
Tel: 01536 264123 Fax: 01 536 264126
E-mail: geoff.cryer@secbattery.com

